



# High Pressure Suspension Mill



## High Pressure Suspension Grinding Mill Overview

High Pressure Suspension Grinding Mill is a new kind of mill, which is invented by our company chief engineer Mr Bai yinghui, who has been engaged in the research and development of grinding machine for many years. This new patent product with high efficiency and low energy consumption opened up an epoch of the international industry pulverizing.



## Applications

High Pressure Suspension Grinding Mill is mainly applied to the powder processing of mineral products in industries of metallurgy, construction, chemistry, and mining etc. It can produce powder from more than 280 kinds of non-flammable and non-explosive mineral materials with Mohs hardness below 9.3 and humidity below 6%, such as barite, limestone, calcite, granite, porcelain clay, basalt, gypsum etc.

## Main Features and Benefits

1. Compared with the common Raymond grinding mill under the same power conditions, the capacity can be increased by 10%; moreover, under the performance of high-pressure springs, the rollers grinding pressure on raw materials can be raised by 800-1200kgf.
2. The final product size ranges from the maximum particle diameter of 0.613mm (30mesh) to the finest diameter of 0.033mm (425 mesh).
3. All the mineral materials with Mohs hardness below 9.3 can be crushed.
4. The grinding device adopts a superposition multi-grade sealing with good sealing performance.
5. Its dust-removing effect fully meets the national dust discharge standard.
6. The classifier is easy for adjustment.

## Technical Data

| Model              |                    | YGM7815   | YGM8314   | YGM9517   | YGM4121   |
|--------------------|--------------------|-----------|-----------|-----------|-----------|
| Roller             | Number(pcs)        | 3         | 3         | 4         | 5         |
|                    | Diameter(mm)       | 260       | 270       | 310       | 410       |
|                    | Height(mm)         | 150       | 140       | 170       | 210       |
| Ring               | Inner Diameter(mm) | 780       | 830       | 950       | 1280      |
|                    | Height(mm)         | 150       | 140       | 170       | 210       |
| Max. Feed Size(mm) |                    | 15        | 20        | 25        | 30        |
| Finished Size(mm)  |                    | 1.6-0.045 | 1.6-0.045 | 1.6-0.045 | 1.6-0.045 |
| Power(kw)          |                    | 18.5      | 22        | 37        | 75        |

Note: This specification is just reference, any changes are subject to the High Pressure Suspension Mill products

## How High Pressure Suspension Mill works

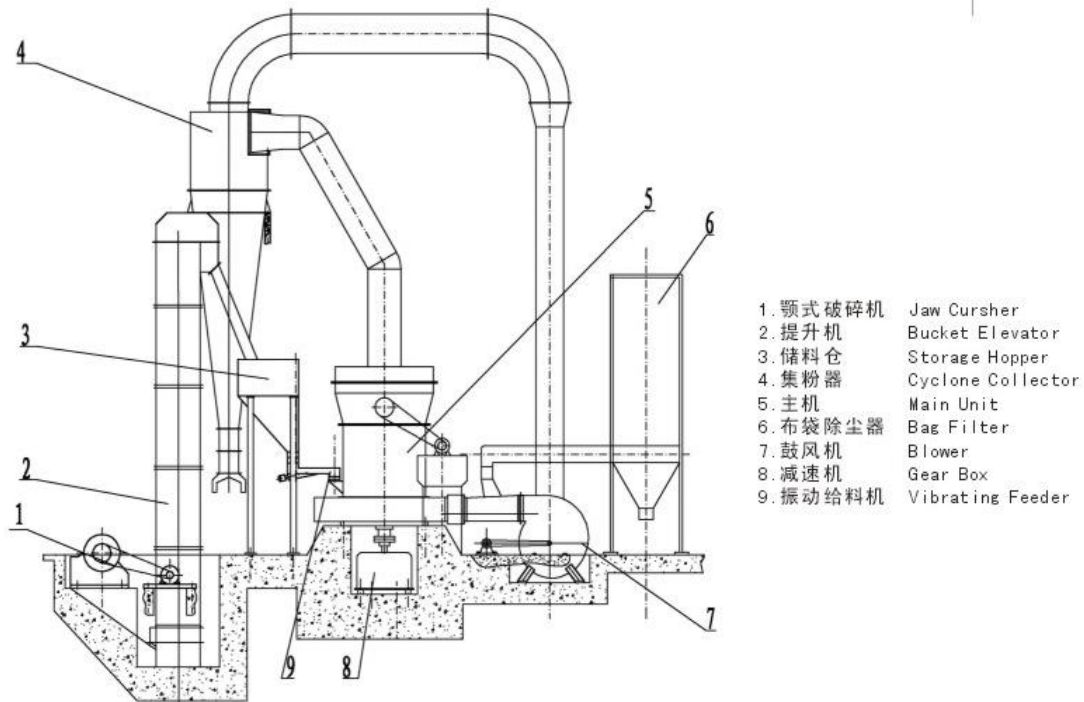

In the mainframe of High Pressure Suspension Mill, there are strong springs with pressure as high as 1000-1500 kg equipped on the roller suspender. When it works, the roller rotates around the principal axis, and clings to ring under the effect of the strong spring and eccentricity. When the materials are sent into the grinding chamber, they are brought to the space between the roller and ring and get grinded. Then the powder grinded will be blown into separator. The fine powder after departed with the air is discharged through the outlet as final product. The large-sized powder falls back for regrinding. The air will be back to the blower for repetition of the above process. The left air will come to the bag filter to get cleaned. When the wear and tear between roller and the ring reaches certain degree, adjust the length of the strong spring, so to keep the invariable pressure between the roller and the ring, to make sure the stable production and the fineness.

## Sales Hot-Line

International Dept.1: Tel: 0086-21-58383098

International Dept.2: Tel: 0086-21-58383028

International Dept.3: Tel: 0086-21-58383058

International Dept.4: Tel: 0086-21-58383003

International Dept.5: Tel: 0086-21-58383022

## E-mail & Fax

E-mail: [sbm@unisbm.com](mailto:sbm@unisbm.com)

Fax: 0086-21-58383058

## Office Address & Zip

Add : No.416 Jianye Road, South Jinqiao Area, Pudong, Shanghai, China

Zip / Postal Code : 201201